



Differential Positive ECL (DPECL) SJ-B2870 Series

Rev. D

Description

The **SJ-B2870 Series** of quartz crystal oscillators provide MECL 10K and 10KH series compatible signals in a ceramic SMD package. Systems designers may now specify space-saving, cost-effective packaged PECL oscillators to meet their timing requirements.

Features

- Wide frequency range—50.0MHz to 100.0MHz
- User specified tolerance available
- Space-saving alternative to discrete component oscillators
- High shock resistance, to 1000g
- 2.5 volt operation
- Metal lid electrically connected to ground to reduce EMI
- MECL 10K and 10KH series compatible output on Pin 3, complement on Pin 1
- Low Jitter - Wavecrest jitter characterization available
- High Reliability - NEL HALT/HASS qualified for crystal oscillator start-up conditions
- High Q Crystal actively tuned oscillator circuit
- Power supply decoupling internal
- No internal PLL avoids cascading PLL problems
- High frequencies due to proprietary design
- Gold plated leads - Solder dipped leads available upon request
- RoHS Compliant, Lead Free Construction (unless solder dipped leads are supplied)

Electrical Connection

Pin	Connection
1	Output Complement
2	V _{EE} /Ground
3	Output
4	V _{CC}

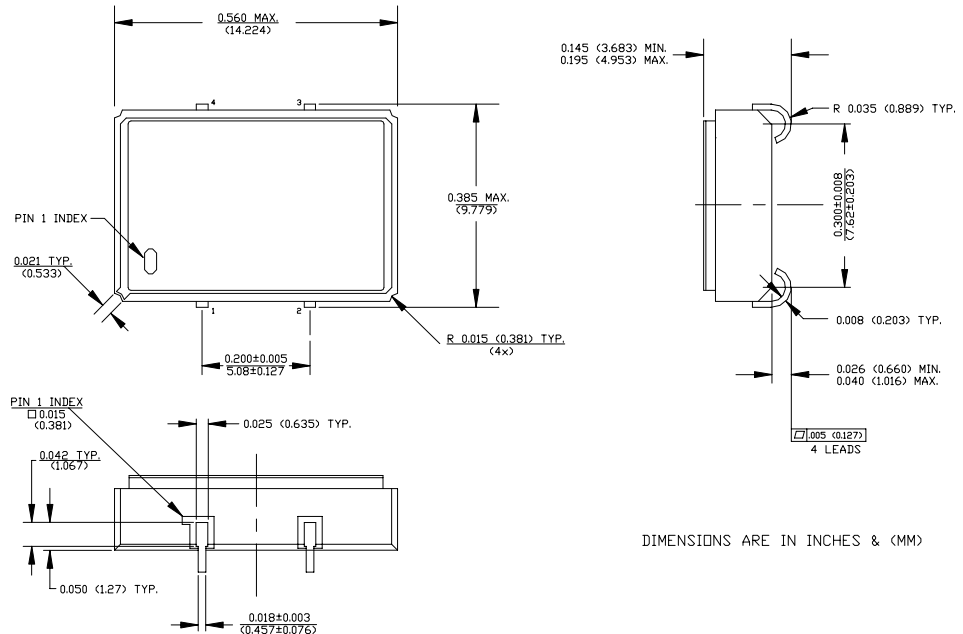

SJ-B2870 Series Continued Differential Positive ECL (DPECL)

Rev. D

Operating Conditions and Output Characteristics

Electrical Characteristics

Parameter	Symbol	Conditions	Min	Typical	Max
Frequency	-----	-----	50.0MHz	-----	100.0MHz
Duty Cycle	-----	@ V _{CC} -1.29V	45/55%	-----	55/45%
Logic 0 ⁽²⁾	V _{OL}	-----	V _{CC} -1.95V	-----	V _{CC} -1.50V
Logic 1 ⁽²⁾	V _{OH}	-----	V _{CC} -1.12V	-----	V _{CC} -0.74V
Rise & Fall Time	tr,tf	20-80%V _O with 50 ohm load to V _{CC} -2V	-----	1.0 ns	2.0 ns
Tpd ⁽⁴⁾	-----	-----	-0.5 ns	-----	+0.5 ns
Jitter, RMS ⁽³⁾	-----	-----	-----	-----	3 psec
Frequency Stability ⁽¹⁾	dF/F	Overall conditions including: voltage, calibration, temp., 10 yr aging, shock, vibration	-100ppm	-----	+100ppm

General Characteristics

Parameter	Symbol	Conditions	Min	Typical	Max
Supply Voltage	V _{CC}	2.5V±5%	2.375V	2.5V	2.625V
Supply Current	I _{CC}	50 ohm termination To 2.00V below V _{CC}	0.0 mA	-----	50 mA
Output current	I _O	Low level Output Current	0.0 mA	-----	±50.0 mA
Operating temperature	T _A	-----	0°C	-----	70°C
Storage temperature	T _S	-----	-55°C	-----	125°C
Power Dissipation	P _D	-----	-----	-----	131 mW
Solder temperature	T _L	4 minutes	-----	-----	253°C
Load	-----	50 Ohm to V _{CC} -2V or Thevenin Equivalent, Bias Required	-----	-----	-----
Start-up time	t _s	-----	-----	2 ms	10 ms

Environmental and Mechanical Characteristics

Mechanical Shock	Per MIL-STD-202, Method 213, Condition E
Thermal Shock	Per MIL-STD-883, Method 1011, Condition A
Vibration	0.060" double amplitude 10 Hz to 55 Hz, 35g's 55Hz to 2000 Hz
Hermetic Seal	Leak rate less than 1 x 10 ⁻⁸ atm.cc/sec of helium
ESD Sensitivity	Human Body Model per ON Semiconductor 10kH series ECL: 500V min.

Footnotes:

- Standard frequency stability (±20,±25,±50ppm & others available)
- V_{OL}, V_{OH}, referenced to ground (V_{EE}) with V_{CC} = 3.3V
- Jitter performance is frequency dependent. Please contact factory for full Wavecrest characterization. RMS jitter bandwidth of 12kHz to 20MHz.
- Tpd is phase shift between the falling edge of pin 3 at V_{CC}-1.29V and rising edge of pin 1 at V_{CC}-1.29V.

Creating a Part Number	
SJ - B287X - FREQ	
Package Code	Tolerance/Performance
SJ 4 J Lead SMD	0 ±100ppm 0-70°C
	1 ±50ppm 0-70°C
	7 ±25ppm 0-70°C
	9 Customer Specific
Input Voltage	A ±20ppm 0-70°C
Code Specification	B ±50ppm -40 to +85°C
A 3.3V	C ±100ppm -40 to +85°C
B 2.5V	
5V	

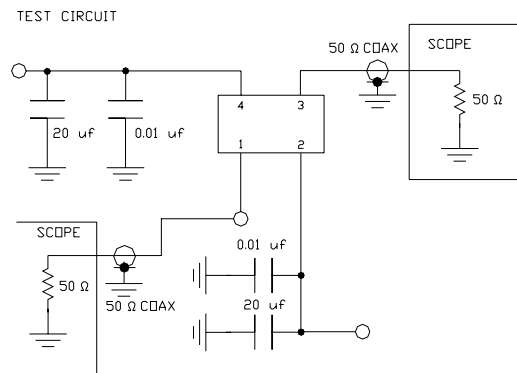

TEST CIRCUIT USES A SPLIT SUPPLY OF +2V AND -1.3V FOR EASE OF TESTING.

SJ-B2870 Series Continued

Max Reflow Profile

