

OD-X8HXXXX-R

Precision, Low Power Consumption, Fast Warm-up SC-cut OCXO in 20x20 mm Through Hole Package

Features

- SC-cut crystal
- Extremely Low Power Consumption (150 mW)
- Fast Warm-up Time (60 s)
- High Stability (up to $\pm 1 \times 10^{-8}$)
- Low Aging (5×10^{-10} /day, 5×10^{-8} /year)
- Very Low Phase Noise
- Sine Wave or HCMOS/TTL output
- 5 MHz to 250 MHz Frequencies Available

Applications

- Telecommunication Systems
- Data Communications
- GPS
- Battery Powered Systems and Equipment
- Instrumentation
- COTS/Dual use

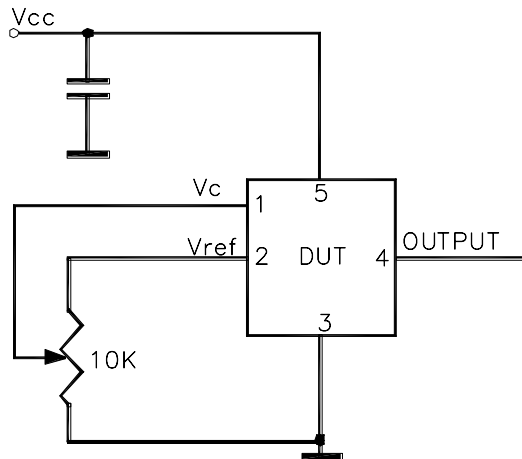
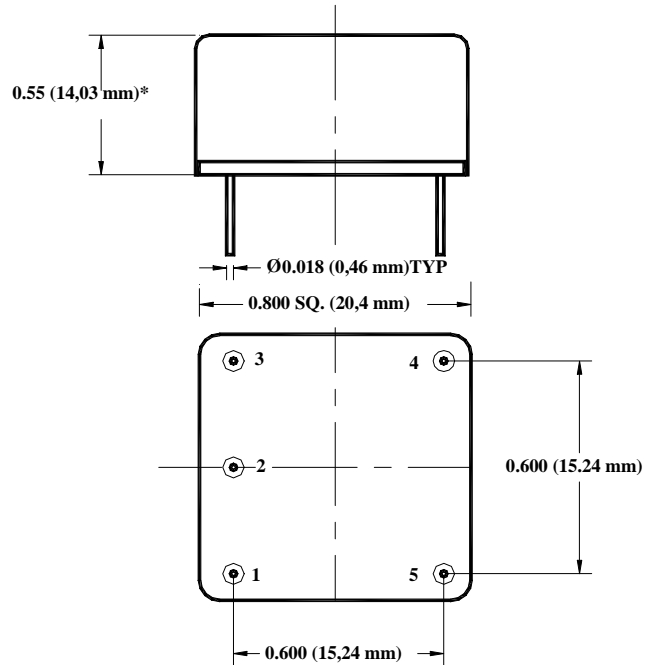

* 12.95mm height available;
please consult factory



OD-X8HXXXX-R Series

Rev. M

Parameter	Symb	Condition	Min	Typ	Max	Unit	Note	
<i>Absolute Maximum Ratings</i>								
Storage temper.	Ts		-60		90	°C		
<i>Electrical (4)</i>								
Frequency	F		5	10.000	250	MHz	1*	
Frequency stability	$\Delta F/F$	vs. Temp.		± 50		ppb	See chart below	
		vs. Supply		2		ppb/V		
Aging		per day			5E-10		after 30 days	
		per year			5E-11		5E-8 available2*	
Allan Variance		.1s		20E-12				
SSB Phase Noise		1Hz		-90		dBc/Hz	3*	
		10 Hz		-125				
		100 Hz		-145				
		1 KHz		-155				
		10 KHz		-165				
Retrace		After 30 minutes			± 10	ppb		
G-sensitivity		worst direction		± 1.0		ppb/G		
Input Voltage	Vcc		4.75 3.15	5.0 3.3	5.25 3.45	V	See chart below to specify	
Power consumption	P	steady state, 25°C start-up		0.15 0.5	0.7	W	Standard Operating Temperature, for Op Temp. 85 °C ad 20%	
Spectral Purity		Subharmonics Harmonics/Sine			-40 -25	dBc	At Higher Frequencies	
Load		10KOhm//15pF (HCMOS/TTL), 50 Ohm (Sinewave)						
Warm-up time	τ	to 0.1ppm accuracy	15	60		s		
Output Waveform		3.3V HCMOS/TTL compatible or Sinewave +5dBm @3.3V/ +8dBm @5V (± 2 dBm)						
Control voltage	Vc	5V 3.3V	0		4.2V 2.8V	V		
Pull range		from nominal F	± 0.5	± 1		ppm		
Setability	Vc0	@25°C, Fnom.	Vref/2-1	Vref/2	Vref/2+1	V		

All parameters for 10 MHz

Environmental and Mechanical

Operating temp. range	-30°C to 70°C Standard, Other options – see chart below
Mechanical Shock	Per MIL-STD-202, 30G, 11ms
Vibration	Per MIL-STD-202, 10G to 2000 Hz
Soldering Conditions	260°C for 10s Max leads only

Electrical Connections

Pin Out	Pin #1-Vc ; Pin#2 – Vref; Pin #3 – GND; Pin #4- Output ; Pin #5- Vcc
---------	--

Notes:

1* Higher frequencies can be achieved either by using higher frequency crystals or by low noise analog harmonic multiplication. Both methods have advantages and drawbacks. If lowest possible phase noise on the noise floor is most important – high frequency crystal will be used. If phase noise close to the carrier and aging are more important – multiplication will be used. Please consult factory for your specific requirement.

2* Aging rate is usually proportional to the operating frequency, unless higher frequency is achieved by multiplication. Keep it in mind while specifying aging.

3* Phase noise deteriorates with frequencies going higher. If analog multiplication is used to achieve higher frequency the phase noise roughly follows the formula of additional 20LogN, where N is a multiplication factor across entire frequency offset range. If higher frequency is achieved by using higher frequency crystal phase noise close to the carrier deteriorates due to the lower Q of the crystal and is usually worse, compared to multiplied solution. On the noise floor, however it remains more or less the same. This design usually starts utilizing multiplication techniques in the range of 25 MHz to 35 MHz.

4. All parameters, unless otherwise specified, are at nominal conditions, ie: T=25°C, Nominal Vcc & Nominal Load.

OD-X8HXXXXX-R Series

Rev.M

Creating a Part Number

OD - X 8H X XX X X - R - FREQ

Package Code

OD 5 pin 20x20mm package

Environmental

Code	Specification
R	RoHS compliant, not designed for reflow

Supply Voltage

Code	Specification
0	5V ± 5%
A	3.3V ± 5%

Aging

Code	Specification
L	1x10 ⁻⁹ /Day
S	5x10 ⁻¹⁰ /Day

Output

Code	Specification
T	TTL/HCMOS
S	Sinewave

Temperature Stability

Code	Specification
17	1x10 ⁻⁷
58	5x10 ⁻⁸
28	2x10 ⁻⁸
18	1x10 ⁻⁸
YZ	Yx10 ^{-Z}

Temperature Range

Code	Specification
A	0°C to 50°C
B	0°C to 70°C
C	-20°C to 70°C
D	-40°C to 85°C
E	-10°C to 60°C
F	-40°C to 80°C
G	-30°C to 70°C

Not all combinations are available. Consult Factory.



**FREQUENCY
CONTROLS, INC.**

357 Beloit Street, P.O. Box 457, Burlington, WI 53105-0457 U.S.A. Phone 262/763-3591 FAX 262/763-2881

Email: nelsales@nelc.com www.nelc.com