

Phase-Locked Ultra Low Phase Noise Multioutput Frequency Reference in 19" Rack Mountable Appliance 1U Form Factor

Product Data Sheet

Features

- Locks to 1 PPS or 10 MHz inputs
- Ultra-Low Phase Noise (ULPN)
- 10 MHz, 160 MHz, and 1 PPS Outputs
- 10 MHz and 80 MHz internal SC-cut OCXO

Applications

- Radar
- 5G device testing
- Instrumentation, Test and Measurement
- Mixed Signal System Reference
- COTS/Dual use

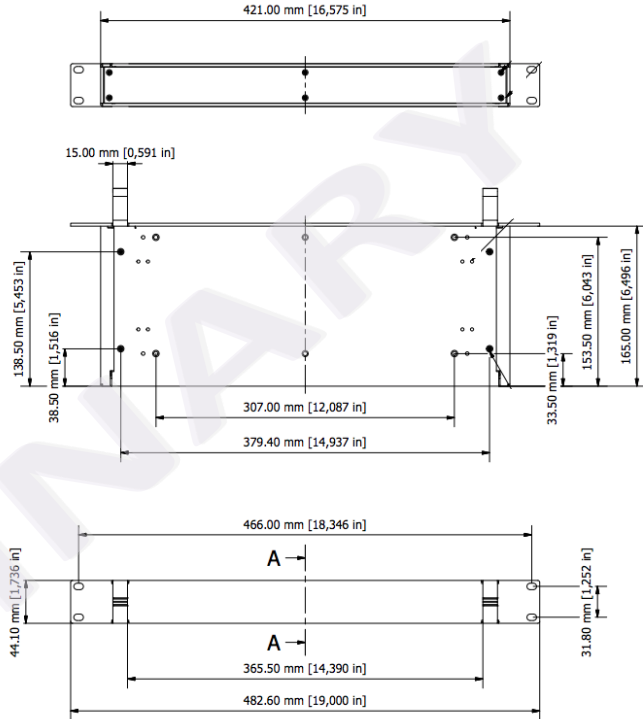

Mechanical Dimensions

Inputs

- 1 PPS IN on SMA Female
- 10 MHz on SMA Female

Outputs

- 160 MHz OUT SMA Female
- 10 MHz OUT SMA Female
- 1 PPS OUT SMA Female

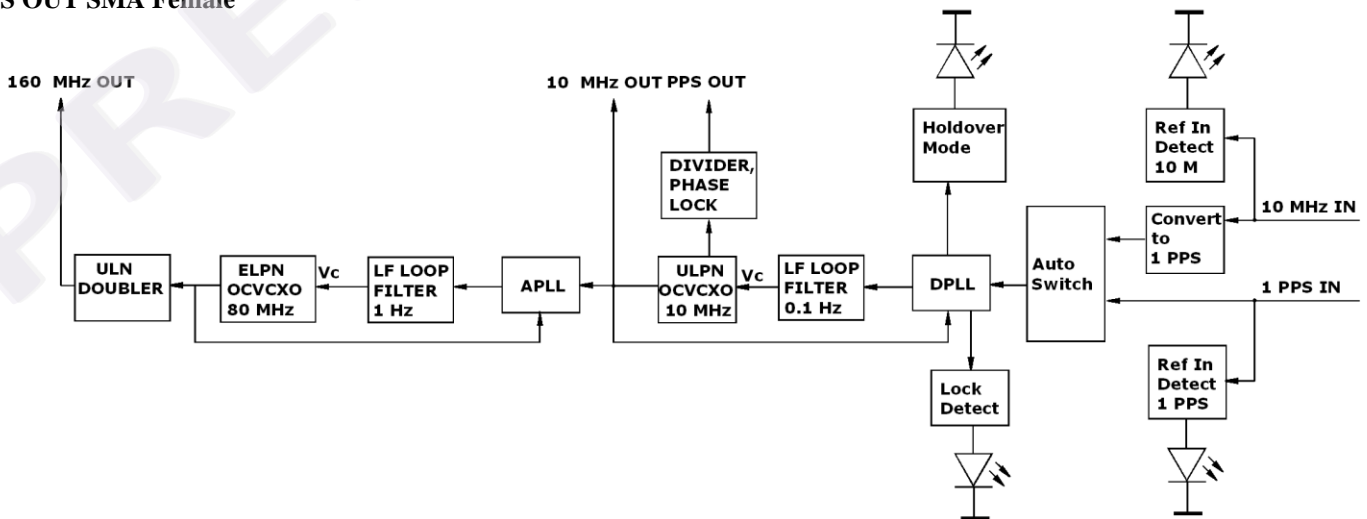

Ultra Low Phase Noise Phase-Locked Frequency Reference

Data Sheet 2309A

Front Panel



Specifications:

Parameter	Symb	Condition	Min	Typ	Max	Unit	Note
Absolute Maximum Ratings							
Power supply	Vp		90		260	V AC	
Operating Temp.	To		10		45	°C	
Storage temper.	Ts		0		70	°C	
Electrical							
	Fpps	1 PPS input		1		Hz	
1PPS in	1 PPS	3.3 V LVC MOS or TTL		2.5		V pk-pk	Green LED
		Pulse Width		1		us	
		Load		50		Ohm	AC coupled
10 MHz input		Sine wave	1		10	V pk-pk	Internally AC coupled 50 Ohm terminated
		Square wave	1		5		
Frequency Capture Range (APR)	$\Delta F/F$	Over All Conditions	± 100			ppb	Includes variation vs. temperature, load, aging 10 years
Allan Deviation		.01s to 1s		1E-12			
Frequency stability	$\Delta F/F$	Locked Holdover	Equal to incoming signal ± 5			ppb	Over temperature
Holdover	τ	8 hours		20		us	
Recommended MAX Input SSB Phase Noise	$\xi(\Delta f)$	10 Hz			-90	dBc/Hz	10 MHz reference
		100 Hz			-120		
		1 KHz			-130		
		10 KHz			-140		
		100 KHz			-140		
Output SSB Phase Noise Improvement Compared to Input Phase Noise adjusted to 10 MHz	$\xi(\Delta f)$	10 Hz		30		dBc/Hz	Cannot improve beyond listed below Output Phase Noise
		100 Hz		40			
		1 KHz		40			
		10 KHz		40			
		100 KHz		40			
Output Frequencies	F10			10.000		MHz	SMA
	F160			160.00			SMA
	PPS			1		Hz	SMA
SSB Phase Noise (achieved after 10 minutes warm-up) Noise floor	$\xi(\Delta f)$	1Hz		-115		dBc/Hz	10 MHz output
		10 Hz		-145			
		100 Hz		-157			
		1 KHz		-162			
		10 KHz		-170			
		100 KHz		-172			

Ultra Low Phase Noise Phase-Locked Frequency Reference

Data Sheet 2309A

		10 Hz 100 Hz 1 KHz 10 KHz 100 KHz		-122 -130 -160 -170 -175	-120 -128 -158 -168 -174		160 MHz output	
Output	F160			160.00		MHz	SMA	
	F10			10.000				
	1 PPS		Buffered internally					
Power Requirements	P	IEC320 on the back	100 to 250 V AC 50/60 Hz Consumption 20 Watts		V AC	Single AC line fuse		
Output Waveform		Sinewave					RF output	
Output Power			+13	+15		dBm	160 MHz	
			+12	+14			10 MHz	
Spectral Purity		Subharmonics Spurious Harmonics		-70 -35	-50 -80 -30	dBc	10 MHz and multiples on 160 MHz Output	
Load	Internally AC coupled 50 Ohm (Sinewave)					RF output		
Warm-up time	τ	to lock on 100 ppb input		3	5	minutes		
Lock Time after warm-up					20	minutes		
Lock Detect			Green LED					
Holdover Mode			Green LED					

Environmental and Mechanical

Operating temp. range	+10°C to +45°C
Storage Temp. Range	0°C to +70°C